



Company23 Anti Surge Boost Control Solenoid Installation Instructions



SPECIAL NOTES:

- The use of a factory service manual is highly recommended. These can be purchased at the dealer, or downloaded online at <http://techinfo.subaru.com>
- Company23 is not responsible for damage done to your vehicle as a result of misuse of this product.
- Company23 does its best to ensure the accuracy of this manual but is not responsible for errors.

Main Installation Steps:

1. Remove factory boost controller and install Company23 boost controller in its place. (See model specific notes and images below for mounting hardware configuration).
2. Connect vacuum lines to boost controller.

Standard Configuration:

- Port 1: Connects to a boost source
- Port 2: Connects to a wastegate (bottom port for external wastegates)
- Port 3: Vents to atmosphere or connects to intake

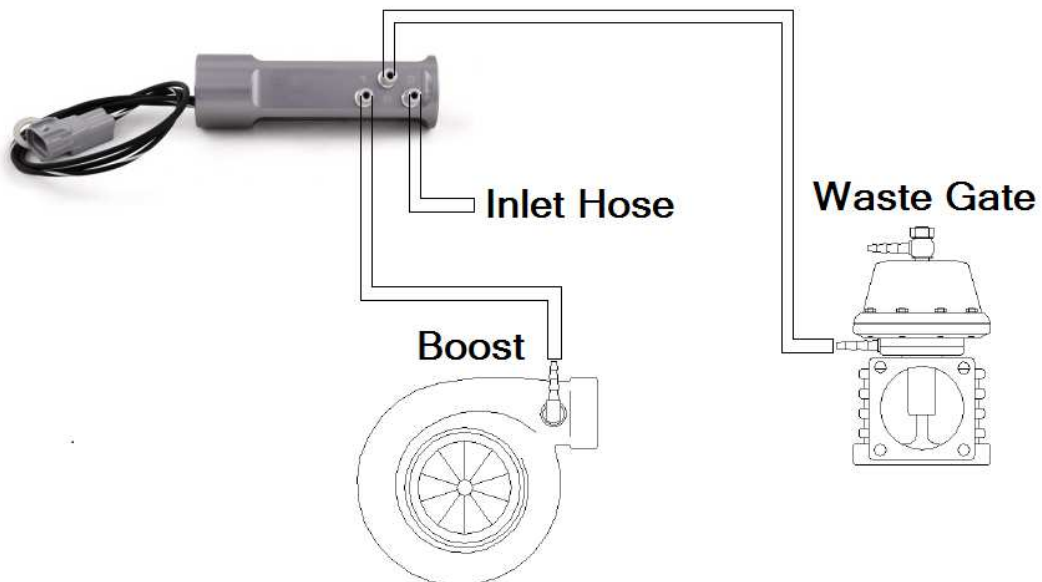



Alternate External Wastegate Configuration:

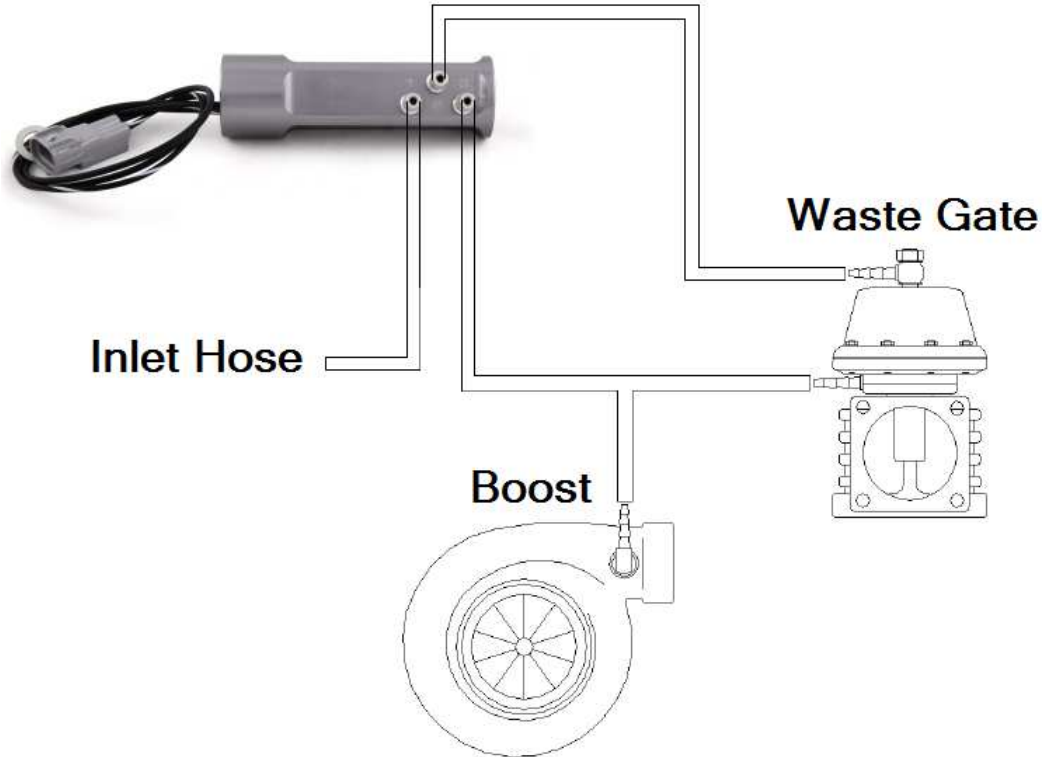

3. Connect the wiring connector to the OEM harness.
4. Connect grounding wire to body ground.
5. Have the car tuned for the new 3 port boost controller.

Model Specific Notes and Images

1. 2002-2007 WRX / 2004-2007 STI / 2004-2008 FXT (Kit 522):

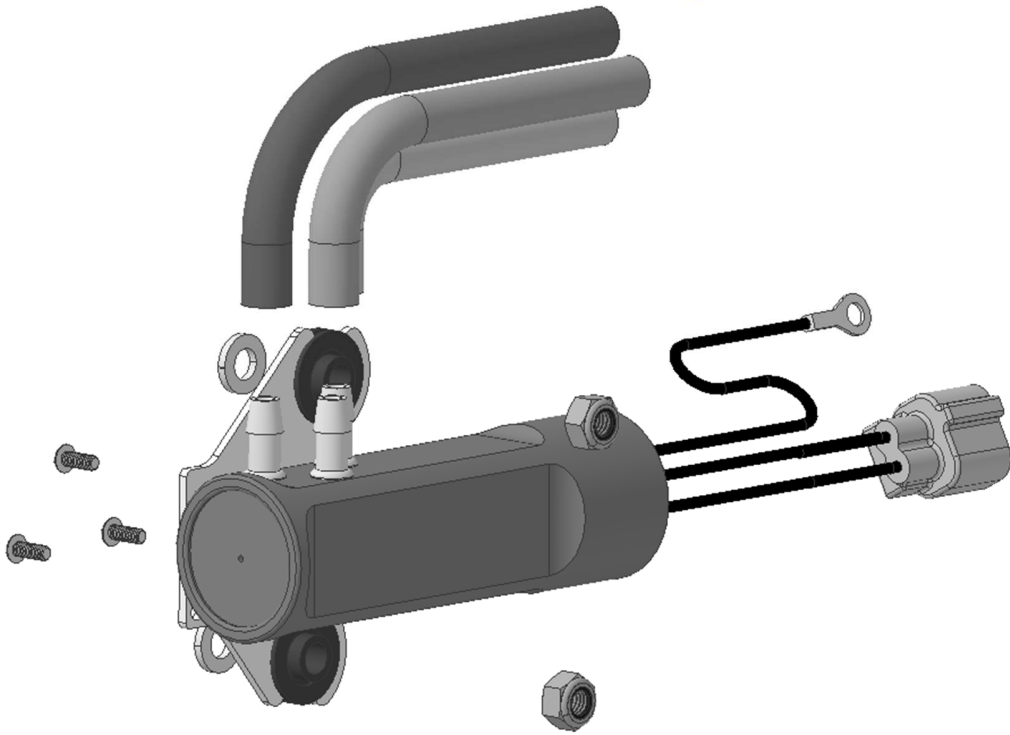

Figure 1: Kit 522 Exploded view

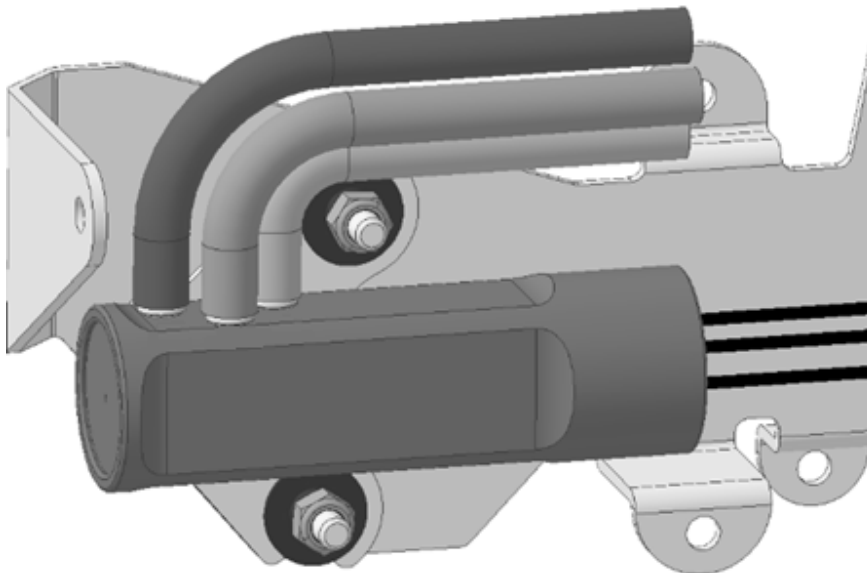

Figure 2: Kit 522 installed in 2002-2003 WRX

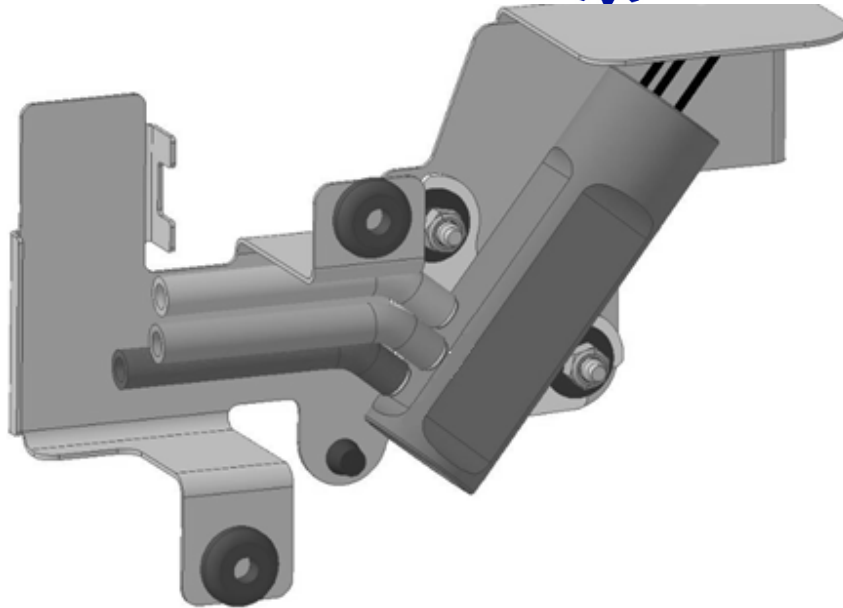

Figure 3: Kit 522 installed in 2004-2007 WRX / 2004-2008 FXT

2. 2005-2009 LGT / 2008-2014 WRX / 2009-2013 FXT (Kit 523):

Note: Replace the OEM vacuum hose from the check valve to the MAP sensor with the supplied vacuum hose.

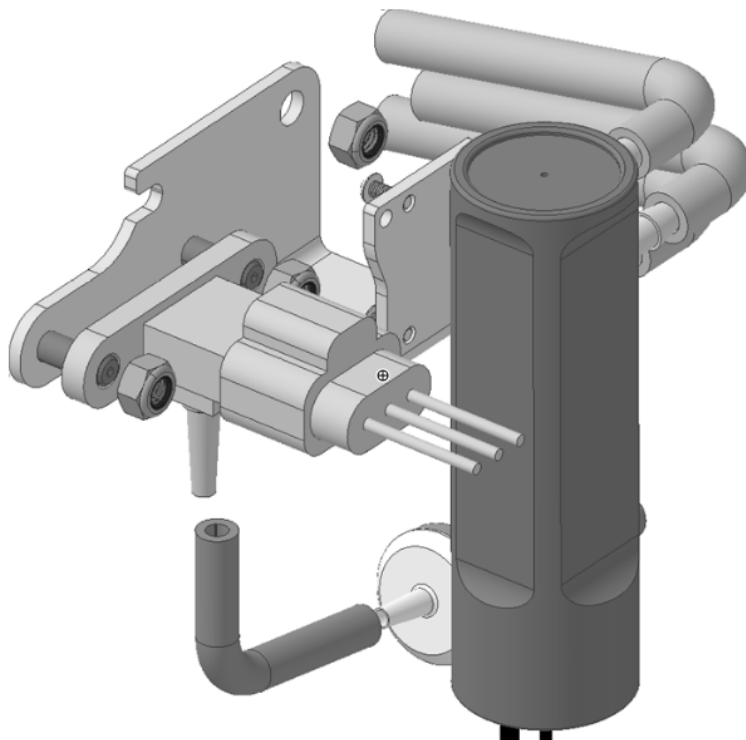

Figure 4: Kit 523 Exploded view

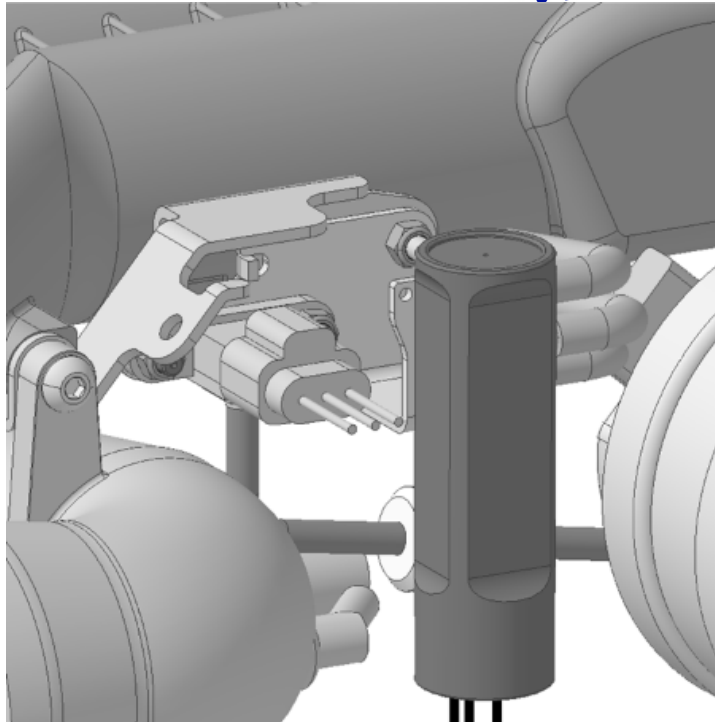

Figure 5: Kit 523 installed in 2005-2009 LGT / 2008-2014 WRX / 2009-2013 FXT

3. 2008-2015 STI INSTRUCTIONS (Kit 524):

Note: Remove the crankcase vent line from its clip on the bracket near the ASBCS wiring and retain it out of the way with the provided zip tie.

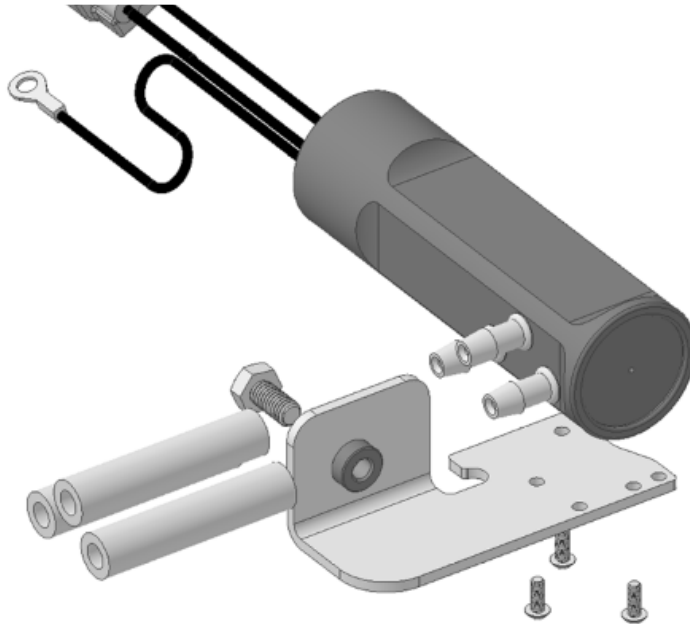

Figure 6: Kit 524 Exploded view

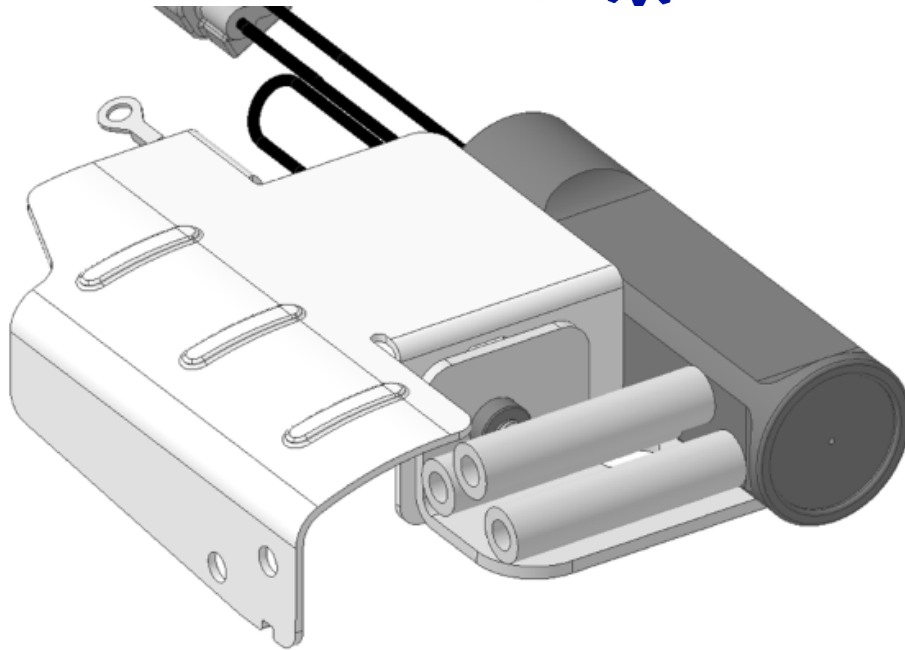

Figure 7: Kit 523 installed in 2008-2015 STI

4. 2015 WRX INSTRUCTIONS (Kit 525):

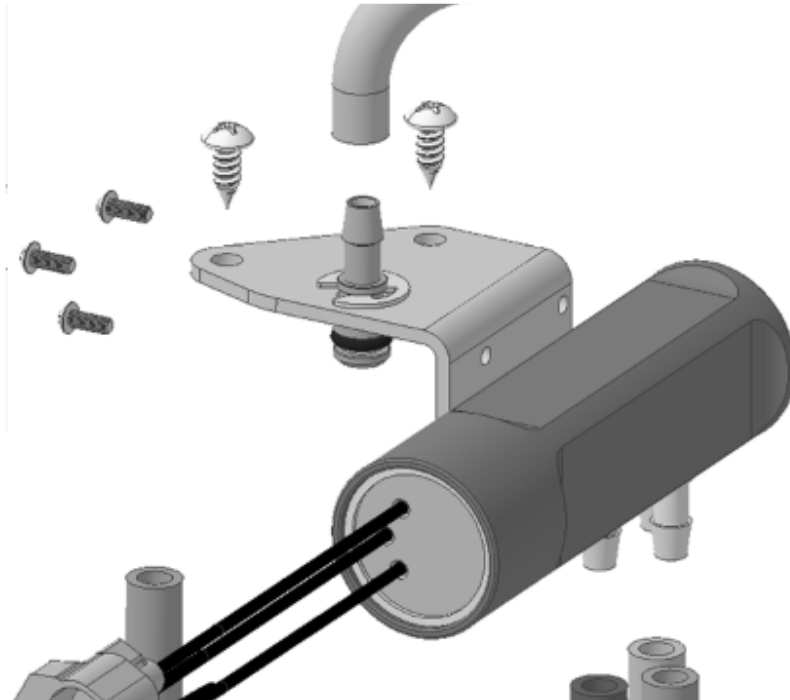

Figure 8: Kit 525 Exploded view

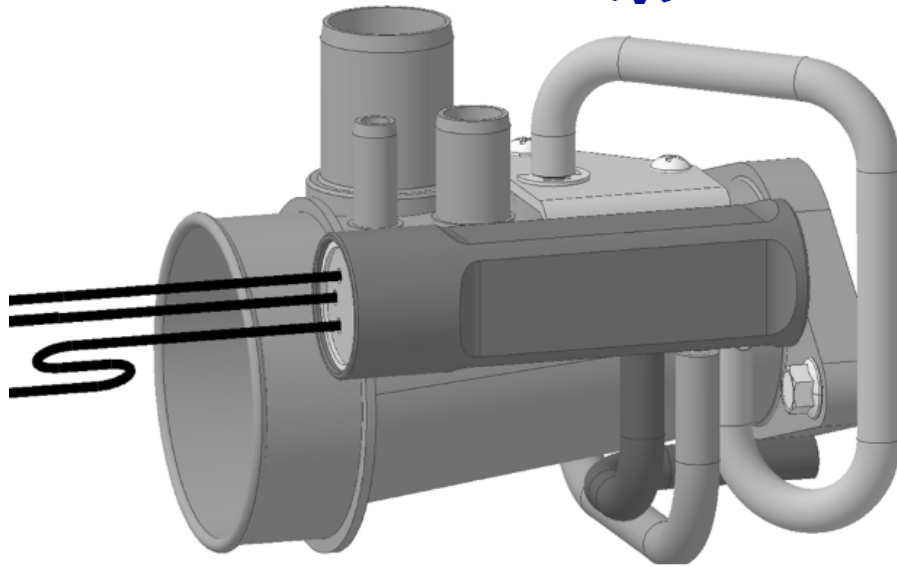

Figure 9: Kit 525 installed in 2015 WRX